

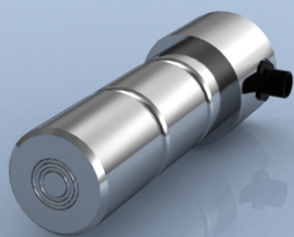

TYPE: CWM-LP



CWM-LP Stainless Steel Container Weighing Load Measuring Pin

Description

The LCM container weighing load pin offers precision force measurement by replacing existing pins in the spreader or headerblock of straddle carriers, container cranes and reach stackers. Each CWM-LP load pin is custom designed to the exact measurements of the load bearing pin it is replacing. They offer a non intrusive method of load measurement, as no modifications are required to existing equipment.

The CWM-LP load pin range is available in ratings from 1te to 50te and are built to exacting standards. They are proof loaded to 150% of normal rated load and are temperature compensated. The load pins employ a full strain gauge bridge as its measurement technology. They are also extremely durable under even the harshest working conditions and have a long operational life.

The load pins have a radial mounted connector so the pins can easily be installed without cables getting in the way, and are supplied with pre-wired cable assemblies for simple and fast connection to the CWM-1 interface module. This also allows untrained personnel to install the load pins, as no system wiring during the installation process is required. Wiring errors are also eliminated.

Specification

Rated load (tonne)	1 tonne to 50 tonnes (higher available on request)
Proof load	150% of rated load
Ultimate breaking load	>300% of rated load
Output	1.5mV/V at rated load (nominal)
Non-linearity	<±0.2 to ±1.5% of rated load typically, depending on pin geometry
Non-repeatability	<±0.04% of rated load
Excitation voltage	10vdc recommended, 15vdc maximum
Bridge resistance	1000Ω
Insulation resistance	>500MΩ @ 500vdc
Operating temperature range	-20 to +70°C
Compensated temperature range	-10 to +70°C
Zero temperature coefficient	<±0.01% of rated load/°C
Span temperature coefficient	<±0.01% of rated load/°C
Environmental protection level	As required (standard IP67)
Connection type	10 metre 4-core screened cable assembly
Wiring connections	+ve supply: Red -ve supply: Blue +ve signal: Green -ve signal: Yellow

Available Options

- Integral signal conditioning
- Special electrical connectors

Features

- Ranges from 1te to 50te
- Stainless steel construction
- Environmentally sealed to IP67
- Supplied with integral connector
- Supplied with pre-wired cable assemblies

Typical Applications

- Container weighing
- Eccentrically loaded container identification
- Twistlock damage identification
- Container overload prevention



CWM-LP Stainless Steel Container Weighing Load Measuring Pin

Dimensions

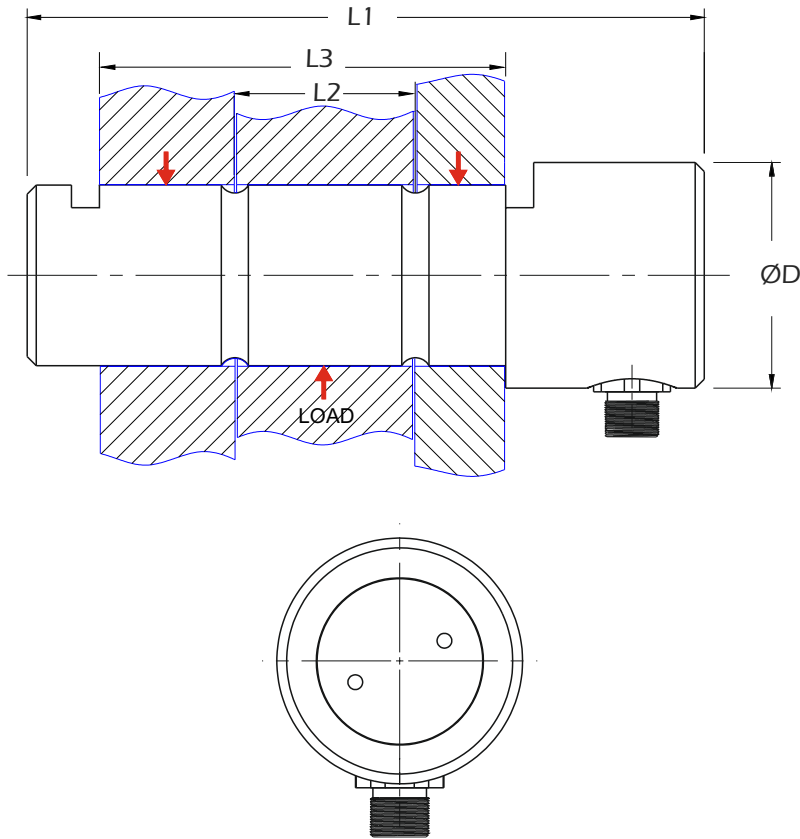

All dimensions are in mm

Rating (tonne)	Part No.	ØD	L1	L2	L3
ALL	LCMXXX	As required	As required	As required	As required

If you would like to receive a quotation for a container weighing load pin, please visit our website at www.lcmsystems.com/lpq and fill in our Load Pin Questionnaire



www.lcmsystems.com

LCM Systems Ltd

Unit 15, Newport Business Park, Barry Way
Newport, Isle of Wight PO30 5GY UK
Tel: +44 (0)1983 249264
sales@lcm systems.com
www.lcm systems.com

LCM Systems (România)

Strada Ștefan Cel Mare 26a,
Tunari, cod.077180, Ilfov, România
Tel: +40 (0)77 4641899
ro@lcm systems.com
www.lcm systems.ro

Due to continual product development, LCM Systems Ltd reserves the right to alter product specifications without prior notice.

Issue No. 1

Issue date: 23/02/2016
APPROVED
(unapproved if printed)



CWM-IF Diecast Aluminium Interface Module (CWM-2)



Description

The LCM container weighing interface module consists of a diecast aluminium converter/junction box with DSC digital load cell conditioning units (one per load pin). The DSC is a high performance digital signal conditioner that takes the mV/V output of the load pin and converts it into an RS485 signal. These DSC cards enable the building of a highly accurate measurement system through the use of the built in linearisation and temperature compensation facilities, which allows calibration to be carried out once the system has been installed.

The interface module itself enables the connection of the load pins and DSC cards to a multi-dropped digital communications bus to offer a convenient and practical solution to the integration of load cells with weighing systems where connection to a tablet, PC, PLC or TOS is required.

Connection of the interface module to the load pins and tablet is easily achieved via the connection pack, which contains all connector and cable assemblies required to connect together all the individual system components. This ensures installation is simple and fast, which reduces costs by eliminating the need for skilled personnel to carry out the commissioning and by reducing equipment downtime.

At LCM Systems we offer a flexible solution to most load monitoring solutions and have many standard interface options available. Please discuss your requirements with our technical or sales team and they will be able to advise and assist you, to offer you the most cost effective and technically compatible system available.

Specification

Bridge excitation (V)	4.25 to 5.25 (5 typical)
Bridge impedance (Ohms)	320 to 5000 (350 typical)
Sensor impedance: 18V supply (Ohms) *	320 to 5000 (350 typical)
Sensor impedance: 12V supply (Ohms) *	320 to 5000 (350 typical)
Bridge sensitivity (mV/V)	-3 to +3
Offset temperature stability (ppm/°C)	5 (10 max)
Gain temperature stability (ppm/°C)	30 (50 max)
Offset stability with time (%FR)	0.0035 (0.016 max)
Gain stability with time (ppmFR/1st year)	300
Non linearity (%FR)	0.0005 (0.0025 max)
Internal Resolution (counts/divisions)	16 million
Resolution @ 1Hz (noise stable)	66,000
Power supply voltage (Vdc)	12/24VDC (9-36VDC)
Power supply noise/ripple (mVac pk-pk)	100
Excitation system	4 wire
Connections	1 x 10m cable assembly per load pin for load cell connection 1 x 25m cable assembly for connection to tablet/PC/PLC
Environmental sealing	Sealed to IP67
Operating temperature range	-40 to +85°C
Storage temperature range	-40 to +85°C
Relative humidity	95% maximum non condensing

* Subject to supply voltage

Available Options

- Various outputs available for integration with terminal operating systems (TOS)
- Special electrical connectors

Features

- RS485 output (various output options available)
- Noise immunity 5x heavy industrial level
- Real mV/V calibration
- Very high stability
- Rated to IP67
- Diecast aluminium construction
- No installation wiring required

Typical Applications

- Container weighing
- Eccentrically loaded container identification
- Twistlock damage identification
- Container overload prevention

LCM Systems Ltd

Unit 15, Newport Business Park
Barry Way, Newport
Isle of Wight PO30 5GY UK
Tel: +44 (0)1983 249264
Fax: +44 (0)1983 249266
sales@lcmsystems.com
www.lcmsystems.com

CWM-IF Diecast Aluminium Interface Module (CWM-2)

CWM-2 Module Use

When used in the CWM-2 system, the CWM-IF interface module output is RS485, providing a 2-wire connection with the data from all load pins available to communicate with a single bus. LCM Systems will supply a DLL file that will enable the system developers to write interface software to suit their needs. Support is given to help expedite this process.

It is possible with the variation of crane and TOS systems on the market that another signal type is required. LCM Systems, in most cases, will have a solution to satisfy this requirement. Some of our standard, alternative solutions include; 4-20mA analogue, CANbus or even a wireless solution interface via RS232, RS485 or USB.

Dimensions

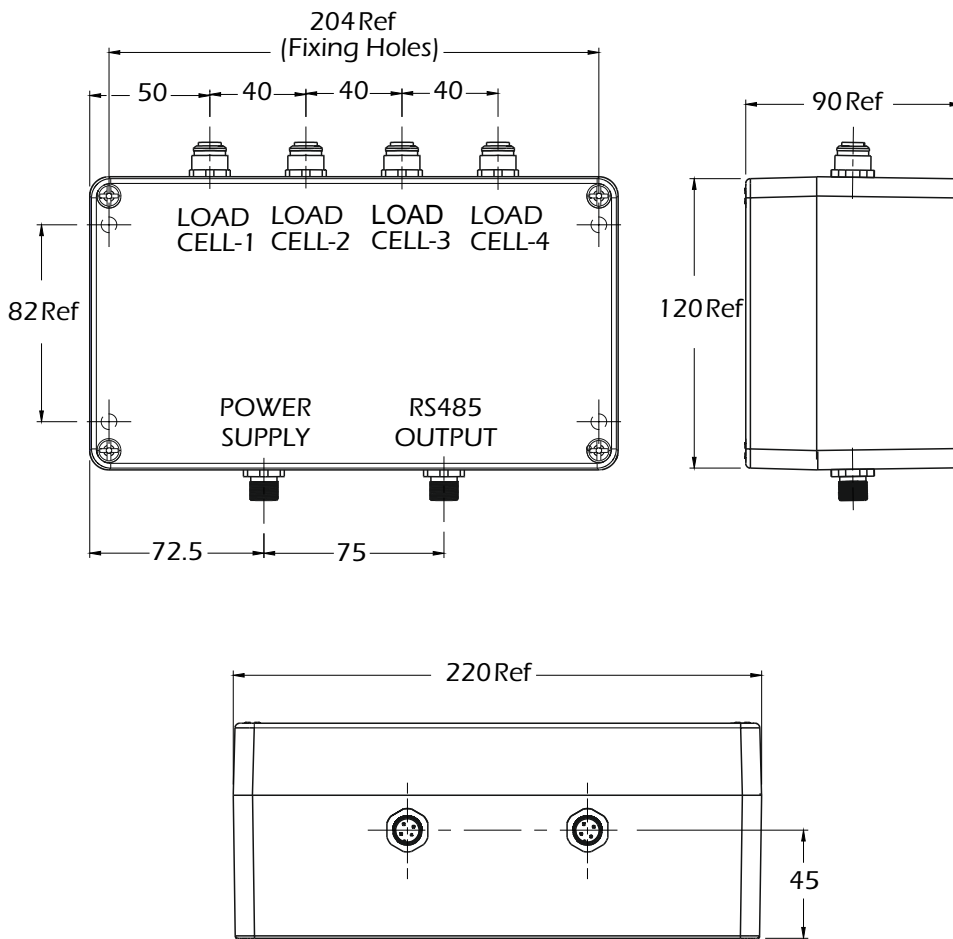

All dimensions are in mm

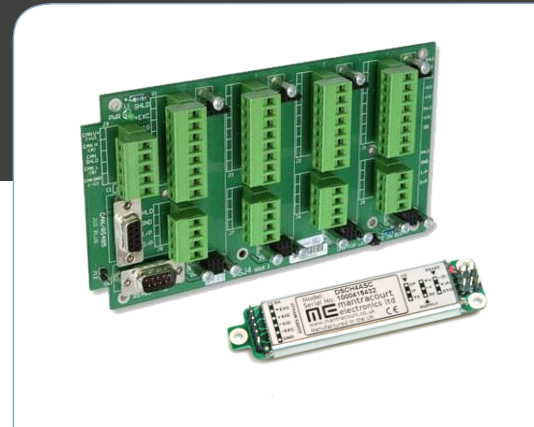

www.lcmsystems.com

LCM Systems Ltd

Unit 15, Newport Business Park, Barry Way
Newport, Isle of Wight PO30 5GY UK
Tel: +44 (0)1983 249264
sales@lcm systems.com
www.lcm systems.com

LCM Systems (România)

Strada Ștefan Cel Mare 26a,
Tunari, cod.077180, Ilfov, România
Tel: +40 (0)77 4641899
ro@lcm systems.com
www.lcm systems.ro

Due to continual product development, LCM Systems Ltd reserves the right to alter product specifications without prior notice.

Issue No. 1

Issue date: 23/02/2016
APPROVED
(unapproved if printed)